





# HEM 1.1

**STAFF REPORT TO THE  
BENTON COUNTY HEARINGS EXAMINER  
William and Cheryle Brasker ADU  
Detached Accessory Dwelling Unit**

**FILE NO:** CUP 2026-007

**MEMO DATE:** March 18, 2026

**HEARING DATE:** April 17, 2026

**APPLICANT:** Paul Fansler, Intrigue Custom Homes, 4025 S Cascade St  
Kennewick, WA 99337.

**OWNERS:** William and Cheryle Brasker, 2422 S 38<sup>th</sup> Ave West Richland, WA  
99353.

**LOCATION:** General Location: The property is located approximately 0.9 miles  
south of the intersection of Broadview Dr and S 38<sup>th</sup> Ave in the West  
Richland area of unincorporated Benton County.  
Address: 2422 S 38<sup>th</sup> Ave Richland, WA 99353.  
Legal: Section 8 of Willamette Heights Lot 137.  
Parcel Number: 108984020137000

**PROPERTY SIZE:** Approximately 2.50 Acres

**AREA TO BE USED:** 796 square feet

**LAND USE:** Residential

**ZONING:** Rural Lands Five-Acre District

**COMPREHENSIVE  
PLAN DESIGNATION:** Rural Remote

**RECOMMENDATION:**

The Planning Division recommends approval of the application request, subject to the suggested twenty-three (23) Findings of Fact and five (5) Conditions of Approval as outlined in this staff report.

**APPLICATION DESCRIPTION:**

The applicant is seeking a Conditional Use Permit (CUP) under BCC 11.42.020(c)(1) to construct a 796 square foot detached Accessory Dwelling Unit (ADU) with a 1,142 square foot attached garage on a property located in the Rural Lands Five-Acre District.

The first floor ADU is proposed to be constructed southeast of the existing 2,425 square foot single-family residence. The proposed structure will be located on a 2.50-acre parcel in the West Richland area of unincorporated Benton County. (HEM 1.4)

The application for CUP 2026-007 (HEM 1.3) was submitted to the Benton County Planning Division on March 12, 2026.

The application was declared complete for processing on March 12, 2026. (HEM 1.5)

The application documents were distributed to reviewing agencies on March 12, 2026. (HEM 1.6)

The Benton County Hearings Examiner Notice of Open Record Hearing for application CUP 2026-007 was published on April 1, 2026 in the Prosser Record Bulletin. (HEM 1.11)

The Notice was mailed to property owners of record within 300 feet of the outer boundaries of the parcel on March 27, 2026

The Open Record Hearing is scheduled for April 17, 2026.

#### **APPLICABLE STANDARDS/ORDINANCES:**

1. *Revised Code of Washington*  
Chapter 36.70A.400 Growth Management—Planning by Selected Counties and Cities  
Any local government, as defined in RCW 43.63A.215, that is planning under this chapter shall comply with RCW 43.63A.215(3).

#### RCW 43.63A.215(3) Accessory apartments—Development and placement—Local governments

Unless provided otherwise by the legislature, by December 31, 1994, local governments shall incorporate in their development regulations, zoning regulations, or official controls the recommendations contained in subsection (1) of this section. The accessory apartment provisions shall be part of the local government's development regulation, zoning regulation, or official control. To allow local flexibility, the recommendations shall be subject to such regulations, conditions, procedures, and limitations as determined by the local legislative authority.

2. *Benton County Comprehensive Plan*  
3.3.2.3 Rural Land Use Designations

Rural Remote is the predominant rural land use in the County. This land is located mostly between the agricultural lands (GMA Agriculture), Rural Transition, and the UGAs. Rural Remote land use is intended to enhance and preserve the County's rural character, which includes rural open space, low densities, wildlife habitat, public open space for outdoor recreational activities, and rural home sites on which a limited range of agricultural activities may be conducted. Allowable density in Rural Remote land use is 1DU/5acres.

#### Section 2.7 Housing

HE Goal 1: Provide for a variety of residential uses and densities consistent with the rural character and lifestyles and a choice of housing types for people of all income levels.

Policy 7: Consider accessory dwelling units as an affordable housing option and look for flexible and innovative ways of integrating accessory dwelling units into single family

residential zones.

### Section 6.4.2 Housing Types

Accessory Dwelling Units. The zoning code permits the establishment of additional living quarters within single family residences to permit persons who, due to a disability or an infirmity, require the assistance of friends, relatives, or a professional nurse to remain in their home and for persons related to the occupant. These units help meet the needs of the disabled, infirm, or elderly in need of assisted care and are currently allowed by ordinance in all residential zones and the agricultural zoning district of Benton County.

### 3. Benton County Code (BCC)

#### Title 11 Zoning

#### Chapter 11.03 Definitions

(2) "Accessory Dwelling Unit" an additional room or set of rooms located within a single-family structure and designed, arranged, occupied, or intended to be occupied by not more than one (1) household as living accommodations independent from any other household and not exceeding 800 square feet in area.

#### Chapter 11.42 General Use Regulations

#### 11.42.020 Accessory Dwelling Unit (ADU).

An accessory dwelling unit shall be allowed on any real property located within unincorporated Benton County that is zoned for single family residences, except for those properties with an Industrial or Commercial zoning designation, thereby meeting the requirements of the Washington State Housing Policy Act of 1993 to incorporate provisions for accessory apartments in the County's zoning ordinance (Title 11 BCC).

(a) All accessory dwelling units authorized herein shall meet the following minimum criteria:

- (1) One (1) accessory dwelling unit is allowed per parcel/lot.
- (2) A single-family dwelling must be located on the parcel/lot where the accessory dwelling unit is to be located.
- (3) The accessory dwelling unit shall not exceed 40% of the total square footage of the single-family home or 800 square feet in size, whichever is smallest.
- (4) The accessory dwelling unit shall consist of no more than one (1) bedroom.
- (5) The accessory dwelling unit shall provide two (2) off-street parking spots.
- (6) An accessory dwelling unit shall be constructed on the site and permanently affixed to the ground by footings and foundation. A recreational vehicle (RV), mobile home, manufactured home, or factory assembled structure is not to be permitted as an accessory dwelling unit.
- (7) The accessory dwelling unit is not allowed on a lot/parcel that has a duplex, multi-family dwelling, a temporary dwelling permit (see BCC 11.42.110), a multiple detached dwelling permit (see BCC 11.42.080) or two (2) or more single-family dwellings.
- (8) The accessory dwelling unit is not allowed to be used in the operation of a home occupation.
- (9) The accessory dwelling unit shall both meet and comply with Benton Franklin Health District standards.
- (10) The accessory dwelling unit shall meet and comply with Benton County Fire Marshal requirements for access.
- (11) The accessory dwelling unit may be permitted as either a ground floor or 2<sup>nd</sup> floor unit.

- (12) Either the accessory dwelling unit or the single-family dwelling shall be occupied by a landowner(s) as his/her primary residence. The landowner shall maintain residency at least six (6) months out of the year and at no time receive rent for or otherwise allow to occupy the landowner(s) unit when absent the rest of the year.
  - (13) If the accessory dwelling unit is connected to the single-family dwelling through a breezeway or similar means, the accessory dwelling unit shall be considered detached and compliance with subsection (c) below is required.
  - (14) The accessory dwelling unit shall comply with the applicable building, fire, critical area, shoreline, and zoning requirements of Title 3, 11, and 15 of Benton County Code.
  - (15) The accessory unit shall not be considered as a dwelling unit when calculating density.
  - (16) The accessory dwelling unit shall comply with requirements in subsection (b) and (c) respectively.
- (c) An accessory dwelling unit detached from the single-family dwelling shall comply with the following:
- (1) All detached accessory dwelling units require approval of a conditional use permit (see Chapter 11.50 BCC).
  - (2) A detached accessory dwelling unit shall comply with the following minimum design standards.
    - (i) The detached accessory dwelling unit may be constructed within an existing outbuilding or be a stand along structure, where the dwelling unit does not share a common wall with the primary single-family dwelling. If the accessory dwelling unit is connected to the single-family dwelling through a breezeway or similar means, the accessory dwelling unit shall be considered detached.
    - (ii) An outside entrance to the accessory dwelling unit is required and be placed at the side or rear of the building, when possible, to maintain the appearance and character of an accessory use.
- (d) The applicant shall record the permit issued for the accessory dwelling unit with the Benton County Auditor's Office. The recording fee shall be paid by the applicant for the accessory dwelling unit. The permit shall include a statement that the accessory dwelling may not be sold as a separate residence until such time as the accessory dwelling is located as the sole residence on a legally subdivided parcel.

## Chapter 11.50 Variance and Conditional Use

### 11.50.040 Conditional Use

(a) Conditional Use Permit – General Standards. The conditional use permit application process allows the Hearings Examiner to review the location and design of certain proposed uses, the configuration of improvements, and the potential impacts on the surrounding area. The application process also allows the Hearings Examiner to ensure that development in each zoning district protects the integrity of that district. The notice, hearing, decision, and enforcement procedures are as set forth herein and in BCC 11.50.050.

Certain uses are classified as conditional uses because of their unusual nature, infrequent occurrence, special requirements, or potentially significant impacts to the environment, public infrastructure, or adjacent properties, and/or possible safety hazards and other similar reasons.

Once granted, a conditional use permit may be transferred by a holder thereof after written notice to the Hearings Examiner; provided the use and location must remain the same and the transferee must continue to comply with the conditions of the permit and, if applicable, the requirements set forth in Chapter 11.51 BCC.

(d) Conditional Use Permit- Permit Granted or Denied. A conditional use permit shall be granted only if the Hearings Examiner can make findings of fact based on the evidence presented sufficient to allow the Hearings Examiner to conclude that, as conditioned, the proposed use:

- (1) Is compatible with other uses in the surrounding area or is no more incompatible than are any other outright permitted uses in the applicable zoning district.
- (2) Will not materially endanger the health, safety, and welfare of the surrounding community to an extent greater than that associated with any other permitted uses in the applicable zoning district.
- (3) Would not cause the pedestrian and vehicular traffic associated with the use to conflict with existing and anticipated traffic in the neighborhood to an extent greater than that associated with any other permitted uses in the applicable zoning district.
- (4) Will be supported by adequate service facilities and would not adversely affect public services to the surrounding area; and
- (5) Would not hinder or discourage the development of permitted uses on neighboring properties in the applicable zoning district as a result of the location, size or height of the buildings, structures, walls, or required fences or screening vegetation to a greater extent than other permitted uses in the applicable zoning district.

It is the applicant's burden to present sufficient evidence to allow the above conclusions to be made. If such evidence is not presented or all necessary reasonable conditions are not identified by the applicant so as to allow the Hearings Examiner to make the conclusions required above, the conditional use application shall be denied.

### **PUBLIC NOTICE:**

The Public Notice Requirements for this application as per BCC 11.50.050(b) are as follows:

1. The Planning Division shall provide written notification for an open record hearing, subject to the rules and regulations set forth in RCW 36.70. Written notice shall be mailed at least twelve (12) days in advance of the open record hearing to the applicant and the owner of the parcel(s) to which the proposed variance or conditional use permit would apply, and to all owners of real property, as shown in the records of the Benton County Assessor, located within a distance of three hundred (300) feet of any portion of the applicable parcel, provided that if the owner of the parcel for which the proposed variance or conditional use permit is requested owns another parcel or parcels adjacent the parcel at issue, notification shall be mailed to owners of real property located within three hundred (300) feet of any portion of such adjacent parcels as well. Failure to receive the notice shall not invalidate any proceedings or decision in connection with the proposed variance or conditional use permit. Notices addressed to the last known owner of record as shown on the County Assessor's records shall be deemed proper notice to the owner of such property; and,

2. By publication of a legal notice in a newspaper of general circulation in the County at least ten (10) days prior to the open record hearing date.

**AGENCY COMMENTS:**

1. The application documents were distributed to the following reviewing agencies on March 12, 2026.
  - a. Benton County Public Works Department
  - b. Benton County Code Enforcement
  - c. Benton County Rural Water Coordinator
  - d. Benton-Franklin Health District
  - e. Benton County Fire District # 4
  - f. Benton County Building Division
  - g. Benton County Fire Marshal
  - h. Benton REA
  - i. City of West Richland
2. The following comments were received from the Benton County Building Division (HEM 1.9):
  - a. The Accessory Dwelling Unit must comply with all current Benton County building and fire codes.
  - b. If you have any questions about these comments, please contact the Benton County Building Division at (509) 735-3500.
3. The following comments were received from Benton County Rural Water Coordinator (HEM 1.8):
  - a. This property is located within the Benton County Rural Water Supply Program area which requires the new dwelling unit to obtain a water mitigation certificate or provide evidence of a valid domestic water right. Additionally, the new dwelling unit will require a water meter to be installed to monitor water usage for compliance with the Rural Water Supply Program.
  - b. If you have any questions about these comments, please contact the Benton County Rural Water Supply Program at (509) 786-5612.
4. The following comment was received from the Benton Franklin Health District (HEM 1.7):
  - a. The site plan provided by the Applicant is not the exact same site plan we have for the septic permit.
  - b. Prior to final occupancy on the ADU, the Septic permit design must be installed and approved by our office.
  - a. If you have any questions about these comments, please contact the Benton Franklin Health District at (509) 460-4205.
5. The following comment was received from the Benton County Fire Marshal (HEM 1.12):
  - a. After the review of CUP 2026-007, it appears that the driveway may exceed 150'. A turn-a-round will be required at the end of the driveway for emergency vehicles. If the driveway exceeds 300' it will also need turnouts for vehicles to pass each other.
  - b. Attached you will find the specifications for private roads and driveways that

exceed 150'. These requirements will need to be met before occupancy will be issued for the new build.

- c. If you have questions about these comments, please contact the Benton County Fire Marshall at (509) 735-3500.
6. The following comment was received from the Benton Rural Electric Association (HEM 1.10):
- a. Benton REA noted a 10 foot utility easement on the site plan.
  - b. If you have any questions about these comments, please contact the Benton REA at (509) 786-2913.

### **FINDINGS OF FACT AND CONDITIONS OF APPROVAL:**

The following Findings of Fact and Conditions of Approval are based on comments received up to the date of this staff memo. Any comments received after the completion of this staff memo or submitted during the advertised public hearing for CUP 2026-007 will need to be considered by the Hearings Examiner and may be added to the suggested Findings of Fact and Conditions of Approval as set forth below. The Hearings Examiner may decide to adopt these as their own or amend/add to these Findings of Fact and Conditions of Approval after holding the open public hearing.

Based on the information received to date, Planning staff recommends approval of the applicant's request with the following suggested findings of fact and conditions of approval:

### **SUGGESTED FINDINGS OF FACT:**

1. The applicant is proposing to construct a 796 square-foot accessory dwelling unit located at 2422 S 38<sup>th</sup> Ave Richland, WA 99353.
2. The applicant is Paul Fansler, Intrigue Custom Homes, 4025 S Cascade St Kennewick, WA 99337.
3. The owners are William and Cheryle Brasker, 2422 S 38<sup>th</sup> Ave West Richland, WA 99353.
4. The property is approximately 2.50 acres in size and is zoned Rural Lands Five-Acre District (RL-5).
5. The property is located in the West Richland area of unincorporated Benton County, approximately 0.9 miles southeast of the intersection of Broadview Dr and S 38<sup>th</sup> Ave (Parcel 108984020137000).
6. The ADU is proposed to be constructed southeast of the existing 2,425 square-foot single-family residence.
7. The ADU will be used as additional living space for the land owners.
8. The Conditional Use Permit (CUP 2026-007) shall comply with the Benton County Critical Area Ordinance, Title 15 BCC.

- a. The proposed ADU is located within Priority Habitat Ferruginous Hawk Breeding Habitat and Shrubsteppe Habitat, but no Priority Habitat areas are evident in the project location.
9. Public notice and application requirements have been met per BCC 11.50 Variance and Conditional Use.
10. The proposed detached ADU is allowable by Conditional Use Permit if approved by the Benton County Hearings Examiner.
11. The detached ADU complies with Benton County Building Division standards and requirements.
12. The application for CUP 2026-007 is consistent with the Growth Management Act, RCW 36.70A, including RCW 36.70A.390.
13. The application for CUP 2026-007 is consistent with RCW 43.63A.215 (3) *Accessory apartments*.
14. The application for CUP 2026-007 is consistent with the goals and policies of the Benton County Comprehensive Plan.
15. The application for CUP 2026-007 is consistent with the requirements of the Benton County Zoning Code.
16. The application for CUP 2026-007 is consistent with the requirements of BCC 11.42.020(a) Accessory Dwelling Units (ADU):
  - a. One (1) detached ADU is proposed for the subject property.
  - b. There is an existing single-family dwelling on the parcel/lot where the detached ADU is to be located.
  - c. The primary single-family dwelling is 2,425 square feet. Forty percent (40%) of 2,425 square feet is 970 square feet. The applicant is proposing a maximum of 796 square feet in the application.
  - d. The detached ADU will be a one-bedroom apartment.
  - e. The applicant is proposing two (2) parking spots to serve the detached ADU.
  - f. The proposal is to construct a 796 square-foot ADU on site that shall be permanently affixed to the ground by footings and foundation.
  - g. No additional dwelling or housing units exist on site or are proposed.
  - h. A home occupation is not planned nor proposed to be operated in the detached ADU.
  - i. The detached ADU must comply with BFHD standards as per the Conditions of Approval.
  - j. The detached ADU and proposed single family dwelling comply with Fire Marshal standards.
  - k. The detached ADU will be a first-floor unit.
  - l. The landowners will reside in the existing single-family dwelling and maintain residency for at least six (6) months out of the year.

- m. The detached ADU complies with applicable building, fire, critical area, shoreline, and zoning requirements.
  - n. The detached ADU complies with the Benton County critical area ordinance, Shoreline Master Program, and zoning regulations.
17. The application for CUP 2026-007 is consistent with requirements in BCC 11.42.020 (c)(2)(i) as the ADU will be located within a standalone structure.
  18. The application for CUP 2026-007 is consistent with requirements in BCC 11.42.020(c)(2)(ii):
    - a. The proposed ADU is located southeast of the primary single-family dwelling.
    - b. The door layout of the structure is adequate for its location and situation, subject to compliance with the Findings of Fact and Conditions of Approval.
  19. The proposed detached ADU is compatible with other uses in the surrounding area and is no more incompatible than any other outright permitted uses in the applicable zoning district.
  20. The proposed detached ADU will not materially endanger the health, safety, and welfare of the surrounding community to an extent greater than that associated with any other permitted uses in the applicable zoning district.
  21. The pedestrian and vehicular traffic caused by the proposed detached ADU will not conflict with existing and anticipated traffic in the neighborhood to an extent greater than that associated with any other permitted uses in the applicable zoning district.
  22. The proposed detached ADU will be supported by adequate service facilities and would not adversely affect public services to the surrounding area.
  23. The proposed detached ADU will not hinder or discourage the development of permitted uses on neighboring properties in the applicable zoning district as a result of the location, size or height of the buildings, structures, walls, or required fences or screening vegetation to a greater extent than other permitted uses in the applicable zoning district.

**SUGGESTED CONDITIONS OF APPROVAL:**

1. The activities on the site shall comply with the submitted site plan and materials submitted for this application.
2. The applicant shall provide written consent to the Planning Division from the legal landowner (if different from applicant) granting permission for the operation of the conditional use prior to issuance of the CUP permit.
3. Either the detached ADU or the single-family dwelling shall be occupied by a landowner(s) as their primary residence. The landowner shall maintain residency at least six (6) months out of the year and at no time receive rent for or otherwise allow others to occupy the landowner(s) unit when absent the rest of the year.
4. The County will provide an ADU agreement to the applicant. The applicant shall sign the agreement before a Notary Public and record the document with the Benton County Auditor's Office prior to the Conditional Use Permit being issued. The recording fee shall

be paid by the applicant. The document will include a statement that the accessory dwelling unit may not be sold as a separate residence until such time as the accessory dwelling is located as the sole residence on a legally subdivided parcel.

5. All required development permits shall be obtained prior to occupying the Accessory Dwelling Unit. This includes approval of permits required by the following, as applicable:
  - a. Benton County Building Division
  - b. Benton County Fire Marshal; for fire and safety regulations.
  - c. Benton Franklin Health District
  - d. Benton County Public Works Department; for road approach permits.
  - e. Benton County Planning Division
  - f. Benton REA

#### **TIME TO COMPLETE CONDITIONS OF APPROVAL:**

The applicant shall have one year to meet all of the Conditions of Approval.

If all conditions of approval have not been met and the Planning Division does not issue the Conditional Use Permit within one (1) year from the time the Hearings Examiner has conditionally approved the Conditional Use Permit, the Hearings Examiner may declare its approval null and void at a regular Hearings Examiner meeting. Prior to doing so, the applicant shall be notified in writing at the applicant's last known address at least twelve (12) days in advance of the upcoming Hearings Examiner meeting.

#### **TRANSFERABILITY:**

This Conditional Use Permit is transferable by the holder.

Should the legal landowner of the parcel change at any time during the life of this Conditional Use Permit the new property owner must provide their written request to the Planning Division for the continuation or termination of the CUP.

Should a new applicant wish to continue operating the CUP, the new applicant must update the Conditional Use Permit application, accept the Conditions of Approval in writing, submit written consent from the legal landowner (if different from applicant) and be approved by the Planning Manager prior to transfer of the permit being allowed.

#### **VIOLATIONS OF CONDITIONS OF APPROVAL:**

The Applicant shall continue to meet all conditions of this Conditional Use Permit while CUP 2026-007 is in effect.

Any violation of the conditions of approval will be processed in accordance with BCC Title 11, Chapter 11.43 Administration and Disposition of Infractions. If the Conditional Use Permit has been issued and violations exist, the Hearings Examiner may revoke the permit after an open record hearing with notice as set forth in BCC 11.50.050(b), as amended. This condition does not foreclose the County's use of other enforcement mechanisms.

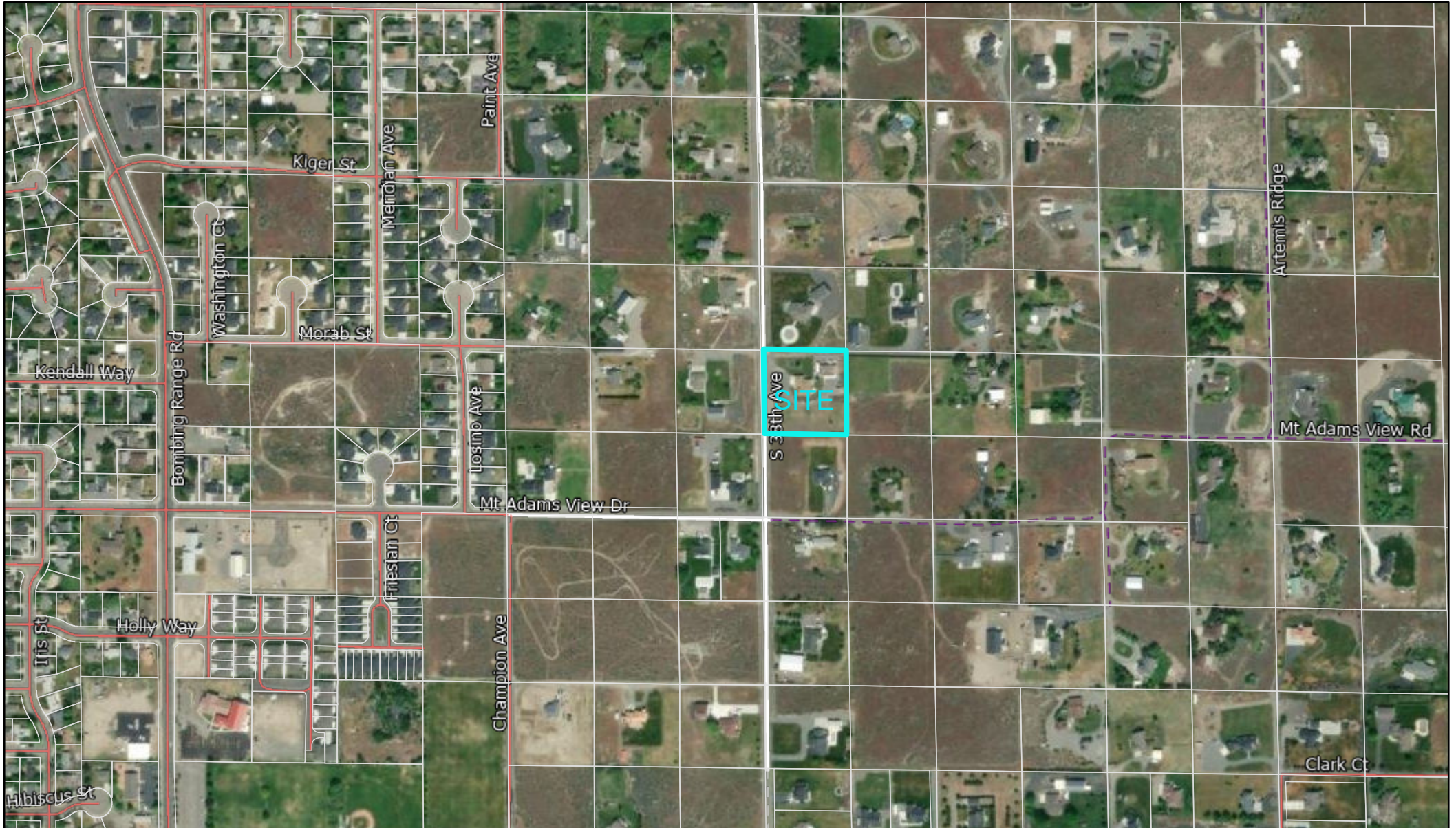

3/12/2026, 10:49:14 AM

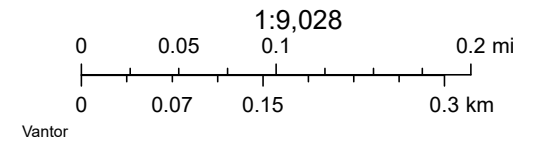

Community Development Department  
102206 East Wisner Parkway  
Kennewick, WA 99338



Planning Division  
(509) 786-5612  
Planning.department@co.benton.wa.us

RECEIVED

MAR 19 2026

Benton County  
Planning Division

HEM 1.3

CONDITIONAL USE PERMIT APPLICATION

File No. CU 2026-007

APPLICANT INFORMATION

Please check the box indicating primary contact person for this application

Name of Applicant/Agent: Paul Fansler-Intrigue Custom Homes

Mailing Address (with City, State & zip): 4025 S. Cascade St. Kennewick, WA 99337

Phone #1: 509-947-4565 Phone #2: \_\_\_\_\_

Email Address(es): pfancoinc@aol.com

Signature: \_\_\_\_\_ Date: \_\_\_\_\_

Name of Property Owner(s) (if different): Bill & Cheryl Brasker

Mailing Address (with City, State & zip): 2422 38th Ave. West Richland

Phone #1: 509-539-0005 Phone #2: \_\_\_\_\_

Email Address(es): brasker@gmail.com

Signature: William Brasker Date: 1-22-2026

Signature: Cheryl Brasker Date: 1/22/26

\*If there are additional owners please copy this section, sign, and attach to the application

If the property is owned by a corporation, trust, partnership or LLC please complete the entity signature block below showing that the person signing has the authority to sign on behalf of the company.

ENTITY SIGNATURE BLOCK

Applicant/Legal Owner name: William & Cheryl Brasker

Applicant/Legal Owner Contact Information: (509) 539-0005 (509) 366-3309

Officer name: Paul Fansler Intrigue Homes Title: Contractor - owner

Signature: William Brasker Date: 1-22-2026

THE ABOVE SIGNED OFFICER OF (name of entity) \_\_\_\_\_ WARRANTS AND REPRESENTS THAT ALL NECESSARY LEGAL AND CORPORATE ACTIONS HAVE BEEN DULY UNDERTAKEN TO PERMIT (name of applicant) \_\_\_\_\_ TO SUBMIT THIS APPLICATION AND THAT THE ABOVE SIGNED OFFICER HAS BEEN DULY AUTHORIZED AND INSTRUCTED TO EXECUTE THIS APPLICATION.

Any information submitted to the Benton County Planning Division is subject to public records disclosure law for the State of Washington (RCW Chapter 42.17) and all other applicable law that may require the release of the documents to the public.



## CONDITIONAL USE PERMIT APPLICATION ADDENDUM DETACHED ACCESSORY DWELLING UNIT

File No. CUF 2021-007

Applicant Name: Bill & Cheryl Brasker

1. Number of Accessory Dwelling Units currently on the property: One
2. Is there a single family dwelling currently on the property?  Yes  No
3. What is the square footage of the main home? 2425
4. What is the square footage of the proposed Accessory Dwelling Unit? 796
5. How many bedrooms will be in the Accessory Dwelling Unit? One
6. Does the landowner currently have any other land use permits? no
7. Will the ADU be using an  Existing well (Well Tag ID BIF-438) or  New well (Well Tag \_\_\_\_\_)
8. Is the well part of a public water system  Yes  No  
If yes, name of public water system \_\_\_\_\_
- 9.. Will the well be a shared well  Yes  No  
If yes, Parcel # where the well is located \_\_\_\_\_ Well Tag ID \_\_\_\_\_

Please describe the purpose and reason for the Accessory Dwelling Unit:

Addition Living Residence to Bill & Cheryl Brasker

**Please provide a site plan that includes the following:**

- Outer boundaries and dimensions of the property including access points
- All existing and planned improvements (including accessory buildings, septic, wells, drainfields, etc)
- Location of roads, easements, etc.
- Distance (in feet) from the ADU to the edges of the parcel and to the main house
- Where parking will be for the main home and the ADU
- All entries/exits for the ADU
- Dimensions and use of each room in the ADU

Any information submitted to the Benton County Planning Division is subject to public records disclosure law for the State of Washington (RCW Chapter 42.17) and all other applicable law that may require the release of the documents to the public.

PARCEL INFORMATION

1. **Subject property address (including city):** 2422 38th Ave. West Richland, WA 99353

2. **Parcel number(s):** 1-0898-402-0137-000

3. **Total Acreage:** 1 Acre

4. **Access:**  County Road  State Road/Highway  Private Road

5. **Utilities:**

**Power:**  Benton PUD  Benton REA  Other: \_\_\_\_\_

**Sewer:**  Septic Tank  City Sewer  Other: \_\_\_\_\_

**Water:**  Individual well(s)  One well serving 2-4 lots  One well serving 5+ lots

City System Provider: \_\_\_\_\_

Private System Provider name and address: \_\_\_\_\_

**Gas:**  No  Yes **PRIVATE SYSTEM: ATTACH APPROVAL DOCUMENTATION**  
Provider name: \_\_\_\_\_

**Irrigation:**  No  Yes  
Provider name: \_\_\_\_\_

6. **Current use(s) on property:** Primary Residential Home

7. **What are you proposing to do that requires a Conditional Use Permit?** Add ADU as primary residence

**For the following proposed uses, please attach the appropriate addendum form:**

Business Use, Detached Accessory Dwelling Unit, Child Care Facility (Type B), Bed & Breakfast, Mineral Extraction (Commercial Sand & Gravel), Commercial Kennel, Winery.

8. **Additional comments or information:** Detached Accessory Dwelling Unit

**If further explanation is needed for any of the questions above, please attach additional pages.**

**(FOR STAFF USE ONLY)** Access: Y N Application Complete: Y N

Critical Areas: N Y: \_\_\_\_\_ Zoning: \_\_\_\_\_

Reviewed by: \_\_\_\_\_ Date: \_\_\_\_\_

Any information submitted to the Benton County Planning Division is subject to public records disclosure law for the State of Washington (RCW Chapter 42.17) and all other applicable law that may require the release of the documents to the public.

# HEM 1.4

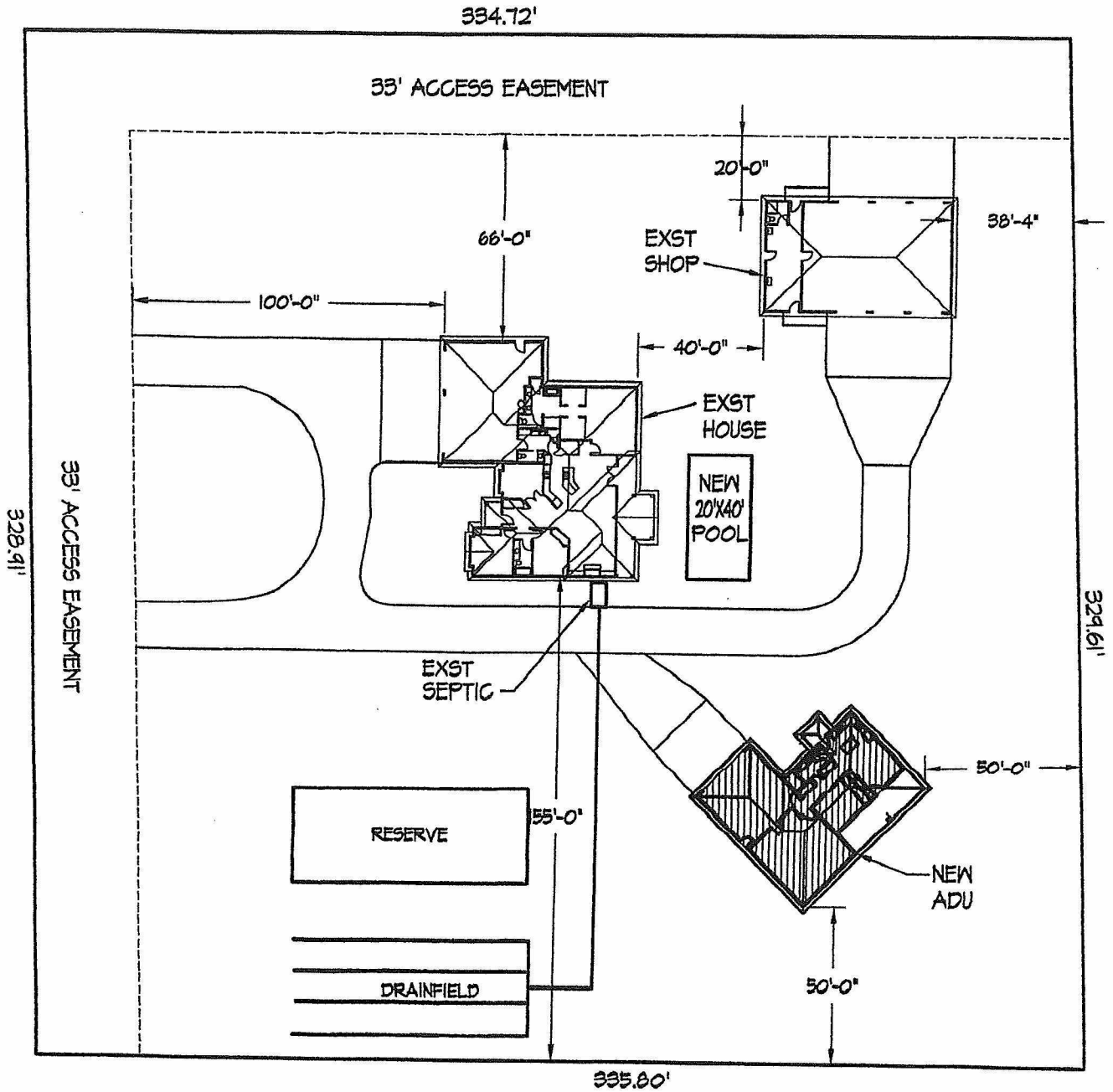

PROPERTY ADDRESS:  
 PARCEL 108984020137000  
 WILLAMETTE HEIGHTS  
 SECTION 8, LOT 137  
 WEST RICHLAND, WA

BILL BRASKER PLOT PLAN		
DRAWN BY: MARK JOHNSON DESIGNS INC.		
SCALE: 1"=50'	DATE: 1/23/26	SHT. 



# HEM 1.5

March 12, 2026

Intrigue Custom Homes  
C/O Paul Fansler  
4025 S Cascade Street  
Kennewick, WA 99337

Email: Pfancoinc@aol.com

RE: Written Determination of Completeness  
File Number: CUP 2026-007

Dear Mr. Fansler,

This office is in receipt of your project permit application for a Conditional Use Permit for a detached Accessory Dwelling Unit. We have determined that the required materials have been submitted and the application is complete. A file number has been assigned (CUP 2026-007) and the review process will now begin.

Although this office has determined that your application is complete, more clarification or information may be needed from you as we go through the review process. Additional information and/or permits may be required from other agencies including, but not limited to, the Benton County Building Division, the Benton-Franklin Health District, and the Washington State Department of Health.

If you have any questions regarding this matter, do not hesitate to contact this office.

Sincerely,

A handwritten signature in black ink, appearing to read "Maya MacDonald".

Maya MacDonald, Associate Planner  
Benton County Planning Division

CC: Brasker@gmail.com



March 12, 2026

## HEM 1.6

Benton County Building Division  
Benton County Code Enforcement  
Benton County Fire District #4  
Benton County Fire Marshal  
Benton County Public Works Department  
Benton County Rural Water Supply Coordinator  
Benton-Franklin Health District  
Benton REA  
City of West Richland

**RE:** Agency review of a Conditional Use Permit application  
**File #:** CUP 2026-007  
**Parcel #:** 1-0898-402-0137-000  
**Applicant:** Intrigue Custom Homes – Paul Fansler

Attached is a Conditional Use Permit application for your agency's review.

The applicant is proposing to construct a 796 sq. ft. detached accessory dwelling unit on a parcel with an existing 2,433 sq. ft. single family residence. The project is located in the West Richland area of unincorporated Benton County within the Rural Lands 5 Acre Zoning District. Parcel number 1-0898-402-0137-000.

PLEASE SUBMIT YOUR COMMENTS to [Planning.department@co.benton.wa.us](mailto:Planning.department@co.benton.wa.us) by **March 26, 2026**. Please reference file number **CUP 2026-007** in all correspondence.

If you have any questions or need more time to review the application, please contact the Planning Division at (509) 786-5612 or to the email above.

Thank you,

*Benton County Planning Division*

**From:** Deana Chiodo <deana.chiodo@bfhd.wa.gov>  
**Sent:** Thursday, March 12, 2026 2:28 PM  
**To:** Planning Department  
**Subject:** [EXTERNAL] RE: Agency Review - CUP 2026-007 - Intrigue Custom Homes  
**Attachments:** Permit # 28115-Brasker.pdf

Good afternoon,

Please see attached septic permit and site plan from the Benton-Franklin Health District for the proposed 1-bedroom ADU. The only comments we have is that the site plan is not the exact same site plan we have for the septic permit, however that wouldn't affect anything on the Conditional Use Permit, I just wanted to bring that to your attention. Prior to final occupancy on the ADU, the Septic permit design must be installed and approved by our office.

---

**From:** Planning Department <Planning.Department@co.benton.wa.us>  
**Sent:** Thursday, March 12, 2026 1:09 PM  
**To:** Brad O'Brien <Brad.Obrien@co.benton.wa.us>; Troy Taylor <Troy.Taylor@co.benton.wa.us>; Code Enforcement <code.enforcement@co.benton.wa.us>; Fire District #4 - Chief Paul Carlyle (pcarlyle@bcfd4.org) <pcarlyle@bcfd4.org>; Gary Tiplady <Gary.Tiplady@co.benton.wa.us>; Cristina Woods <Cristina.Woods@co.benton.wa.us>; Dylan Krantz <Dylan.Krantz@co.benton.wa.us>; Shane Elledge <Richard.Elledge@co.benton.wa.us>; Rural Water Supply Program <Rural.Water@co.benton.wa.us>; JoDee Peyton <Jodeer@bfhd.wa.gov>; Erin Hockaday <erin.hockaday@bfhd.wa.gov>; Deana Chiodo <deana.chiodo@bfhd.wa.gov>; jbrown@ci.benton-city.wa.us; Benton REA - Chris Cooke <CCooke@bentonrea.org>; Eric Mendenhall <emendenhall@westrichland.org>  
**Cc:** Andrea Watts <Andrea.Watts@co.benton.wa.us>  
**Subject:** Agency Review - CUP 2026-007 - Intrigue Custom Homes

Good afternoon,

Attached you will find the necessary application materials for Intrigue Custom Homes on behalf of Bill and Cheryle Brasker, who are requesting a Conditional Use Permit for a detached 796 sq. ft. accessory dwelling unit at 2422 S 38<sup>th</sup> avenue in West Richland.

Please review and provide any comments by **March 26, 2026.**

Have a wonderful week,

**Nikki Relyea**

*Associate Planner*

Benton County Community Development Department

Planning Division

[Nikki.Relyea@co.benton.wa.us](mailto:Nikki.Relyea@co.benton.wa.us)

[Planning.Department@co.benton.wa.us](mailto:Planning.Department@co.benton.wa.us)

(509) 786-5612

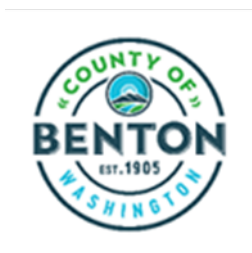

**From:** Rural Water Supply Program  
**Sent:** Monday, March 16, 2026 9:06 AM  
**To:** Planning Department  
**Subject:** RE: Agency Review - CUP 2026-007 - Intrigue Custom Homes

Good morning,

This property is located within Benton County's Rural Water Supply Program which requires the new dwelling unit to obtain a water mitigation certificate or provide evidence of a valid domestic water right for the new dwelling unit. Additionally, the new dwelling unit will require a water meter to be installed to monitor water usage for compliance with the Rural Water Supply Program.

Please contact Maya MacDonald at 509-786-5612 with the Planning Division for more information.

Thank you,

**From:** Troy Taylor  
**Sent:** Tuesday, March 17, 2026 8:47 AM  
**To:** Planning Department  
**Subject:** RE: Agency Review - CUP 2026-007 - Intrigue Custom Homes

Building- comply with all current Benton County and fire codes

---

**From:** Planning Department <Planning.Department@co.benton.wa.us>  
**Sent:** Thursday, March 12, 2026 1:09 PM  
**To:** Brad O'Brien <Brad.Obrien@co.benton.wa.us>; Troy Taylor <Troy.Taylor@co.benton.wa.us>; Code Enforcement <code.enforcement@co.benton.wa.us>; Fire District #4 - Chief Paul Carlyle (pcarlyle@bcfd4.org) <pcarlyle@bcfd4.org>; Gary Tiplady <Gary.Tiplady@co.benton.wa.us>; Cristina Woods <Cristina.Woods@co.benton.wa.us>; Dylan Krantz <Dylan.Krantz@co.benton.wa.us>; Shane Elledge <Richard.Elledge@co.benton.wa.us>; Rural Water Supply Program <Rural.Water@co.benton.wa.us>; Benton Franklin Health District - JoDee Peyton <Jodeer@bfhd.wa.gov>; erin.hockaday@bfhd.wa.gov; deana.chiodo@bfhd.wa.gov; jbrown@ci.benton-city.wa.us; Benton REA - Chris Cooke <CCooke@bentonrea.org>; Eric Mendenhall <emendenhall@westrichland.org>  
**Cc:** Andrea Watts <Andrea.Watts@co.benton.wa.us>  
**Subject:** Agency Review - CUP 2026-007 - Intrigue Custom Homes

Good afternoon,

Attached you will find the necessary application materials for Intrigue Custom Homes on behalf of Bill and Cheryle Brasker, who are requesting a Conditional Use Permit for a detached 796 sq. ft. accessory dwelling unit at 2422 S 38<sup>th</sup> avenue in West Richland.

Please review and provide any comments by **March 26, 2026.**

Have a wonderful week,

**Nikki Relyea**

*Associate Planner*

Benton County Community Development Department

Planning Division

[Nikki.Relyea@co.benton.wa.us](mailto:Nikki.Relyea@co.benton.wa.us)

[Planning.Department@co.benton.wa.us](mailto:Planning.Department@co.benton.wa.us)

(509) 786-5612



**From:** Chris Cooke <ccooke@bentonrea.org>  
**Sent:** Wednesday, March 18, 2026 8:06 AM  
**To:** Planning Department  
**Subject:** RE: [External] Agency Review - CUP 2026-007 - Intrigue Custom Homes  
**Attachments:** BREAs Comments\_2026-007 Intrigue.pdf

Good morning,

Please see BREAs comments attached.

Thank you,

**CHRIS COOKE**

**Office:** 509-786-2913

**Direct:** 509-781-6735



6095 W Van Giesen St | West Richland, WA 99353

---

**From:** Planning Department <Planning.Department@co.benton.wa.us>  
**Sent:** Thursday, March 12, 2026 1:09 PM  
**To:** Brad O'Brien <Brad.Obrien@co.benton.wa.us>; Troy Taylor <Troy.Taylor@co.benton.wa.us>; Code Enforcement <code.enforcement@co.benton.wa.us>; Fire District #4 - Chief Paul Carlyle (pcarlyle@bcfd4.org) <pcarlyle@bcfd4.org>; Gary Tiplady <Gary.Tiplady@co.benton.wa.us>; Cristina Woods <Cristina.Woods@co.benton.wa.us>; Dylan Krantz <Dylan.Krantz@co.benton.wa.us>; Shane Elledge <Richard.Elledge@co.benton.wa.us>; Rural Water Supply Program <Rural.Water@co.benton.wa.us>; Benton Franklin Health District - JoDee Peyton <Jodeer@bfhd.wa.gov>; erin.hockaday@bfhd.wa.gov; deana.chiodo@bfhd.wa.gov; jbrown@ci.benton-city.wa.us; Chris Cooke <ccooke@bentonrea.org>; Eric Mendenhall <emendenhall@westrichland.org>  
**Cc:** Andrea Watts <Andrea.Watts@co.benton.wa.us>  
**Subject:** [External] Agency Review - CUP 2026-007 - Intrigue Custom Homes

**This message came from outside of Benton REA.**

Good afternoon,

Attached you will find the necessary application materials for Intrigue Custom Homes on behalf of Bill and Cheryle Brasker, who are requesting a Conditional Use Permit for a detached 796 sq. ft. accessory dwelling unit at 2422 S 38<sup>th</sup> avenue in West Richland.

Please review and provide any comments by **March 26, 2026.**

Have a wonderful week,

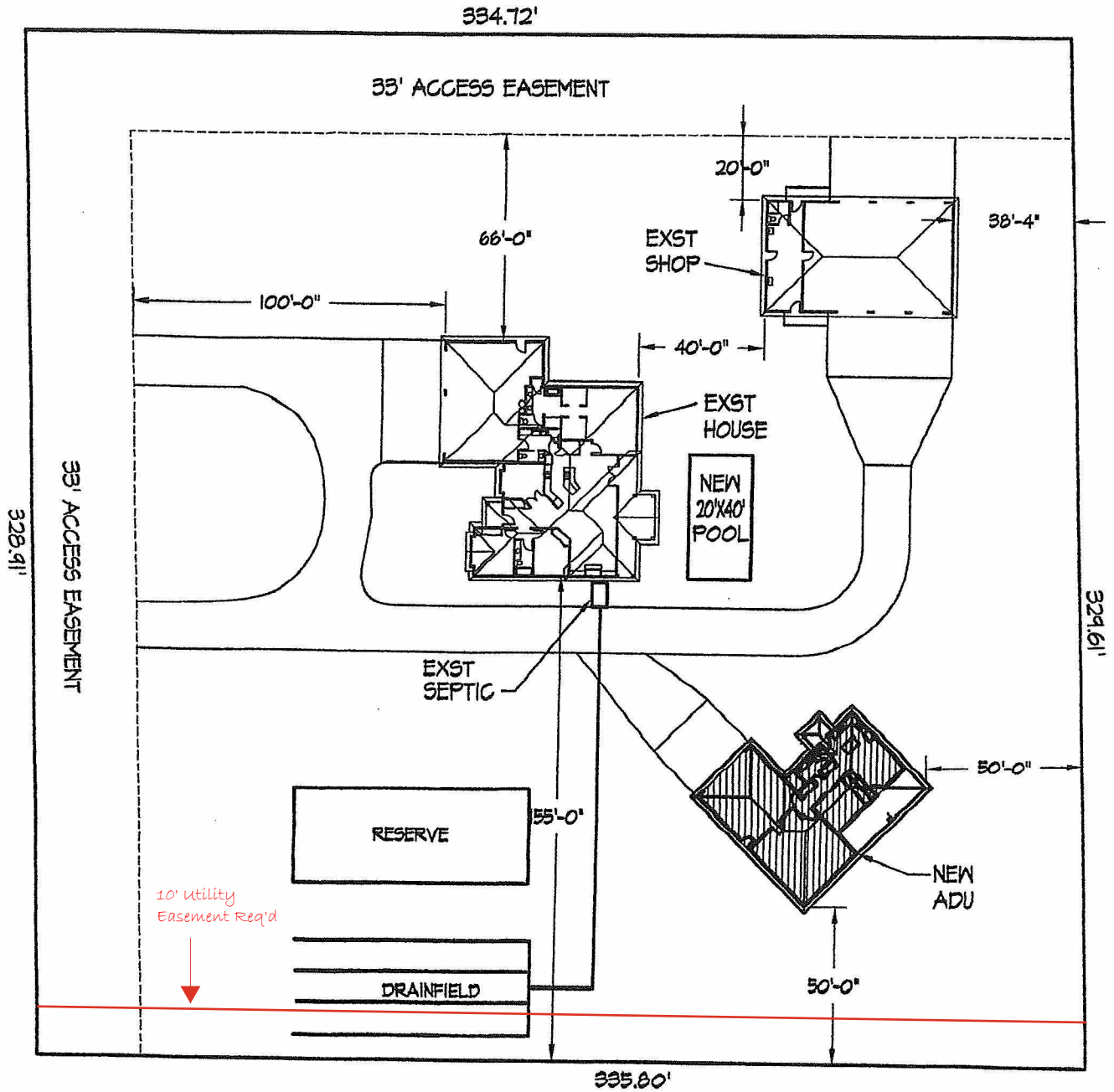

PROPERTY ADDRESS:  
PARCEL 108984020137000  
WILLAMETTE HEIGHTS  
SECTION 8, LOT 137  
WEST RICHLAND, WA

BILL BRASKER PLOT PLAN		
DRAWN BY: MARK JOHNSON DESIGNS INC.		
SCALE: 1"=50'	DATE: 1/23/26	SHT. 

**From:** Shane Elledge  
**Sent:** Monday, March 23, 2026 10:35 AM  
**To:** Planning Department  
**Subject:** RE: Agency Review - CUP 2026-007 - Intrigue Custom Homes

Good morning,

Public works has no comments on the CUP.  
They will need to apply for a road approach permit.

Thank you.



**R. Shane Elledge, LSIT** • *Engineering Associate*  
Benton County Public Works  
102206 Wisner Parkway , Kennewick WA, 99338  
(509) 786-5611 Ext: 5531

---

**From:** Planning Department <Planning.Department@co.benton.wa.us>  
**Sent:** Thursday, March 12, 2026 1:09 PM  
**To:** Brad O'Brien <Brad.Obrien@co.benton.wa.us>; Troy Taylor <Troy.Taylor@co.benton.wa.us>; Code Enforcement <code.enforcement@co.benton.wa.us>; Fire District #4 - Chief Paul Carlyle (pcarlyle@bcfd4.org) <pcarlyle@bcfd4.org>; Gary Tiplady <Gary.Tiplady@co.benton.wa.us>; Cristina Woods <Cristina.Woods@co.benton.wa.us>; Dylan Krantz <Dylan.Krantz@co.benton.wa.us>; Shane Elledge <Richard.Elledge@co.benton.wa.us>; Rural Water Supply Program <Rural.Water@co.benton.wa.us>; Benton Franklin Health District - JoDee Peyton <Jodeer@bfhd.wa.gov>; erin.hockaday@bfhd.wa.gov; deana.chiodo@bfhd.wa.gov; jbrown@ci.benton-city.wa.us; Benton REA - Chris Cooke <CCooke@bentonrea.org>; Eric Mendenhall <emendenhall@westrichland.org>  
**Cc:** Andrea Watts <Andrea.Watts@co.benton.wa.us>  
**Subject:** Agency Review - CUP 2026-007 - Intrigue Custom Homes

Good afternoon,

Attached you will find the necessary application materials for Intrigue Custom Homes on behalf of Bill and Cheryle Brasker, who are requesting a Conditional Use Permit for a detached 796 sq. ft. accessory dwelling unit at 2422 S 38<sup>th</sup> avenue in West Richland.

Please review and provide any comments by **March 26, 2026.**

Have a wonderful week,



**Date: March 23, 2026**

# HEM 1.12

**Nikki:**

**After the review of CUP 2026-007, it appears that the driveway may exceed 150'. A turn-a-round will be required at the end of the driveway for emergency vehicles. If the driveway exceeds 300' it will also need turnouts for vehicles to pass each other. Attached you will find the specifications for private roads and driveways that exceed 150'. These requirements will need to be met before occupancy will be issued for the new build.**

**If you have any questions about these requirements, I will be happy to help in any way I can.**

**Thank you,**

**Gary Tiplady  
Benton County Fire Marshal  
Building Inspector II  
509-735-3500  
[Gary.Tiplady@co.benton.wa.us](mailto:Gary.Tiplady@co.benton.wa.us)**

**Re: Intrigue Custom Homes – CUP 2026-007**



## **BCC 3.18.045**

### **"Minimum Driveway and Private Road Requirements"**

**Procedure:** Upon the Benton County Fire Marshal's office receiving a submittal from the Benton County Planning Department for a Sub-Division or the Benton County Building Department, for a new Residential Structure a review will be conducted to determine if the proposed Private Road or Driveway will meet the county requirements of BCC 3.18.045.

**Benton County Code 3.18.045 MINIMUM ROAD REQUIREMENTS.** ("Private Road" means a road, driveway, or any form of access easement more than one-hundred and fifty feet (150') in length that is not dedicated to and maintained by Benton County.)

(a) Except as otherwise provided in this chapter, the minimum acceptable improved surface for a private road shall be twenty feet in width that is graded and with two inches of compacted recycled concrete asphalt or two inches of base course crushed surfacing in accordance with the specifications set forth in **Standard Specifications for Road, Bridges and Municipal Construction** published by the **Washington State Department of Transportation**, as now in effect or hereafter amended.

(b) The minimum improved surface of a private road may be twelve feet in width surfaced with the materials set forth in subsection (a) above, but only if the private road serves six or fewer dwelling units (a duplex constitutes two dwelling units) and turnouts ten feet wide and thirty feet in length, surfaced in the same manner as the remainder of the private road, are placed every three hundred feet from a public road.

(c) If a private road has any curves or turns, the required improved width of any such private road shall be as determined and set forth in writing by the Fire Marshal to a width deemed necessary to allow the appropriate firefighting equipment to safely navigate such curves or turns. If no such written determination is requested of and made by the Fire Marshal, then a private road with curves or turns must be improved to a width of twenty feet in accordance with the standards set forth in subsection (a) above.

(d) All private roads must terminate in a turnaround that shall not require more than one backing up motion for a fire truck of at least thirty-seven feet in length from bumper to bumper to completely turn around.

**All private roads must terminate in a turnaround that shall not require more than one backing up motion for a fire truck of at least thirty-seven feet in length from bumper to bumper to completely turn around.**

(e) All private roads shall be constructed to applicable standards set forth above and all conditions of approval of an encroachment permit shall be satisfied prior to any certificate of occupancy being issued for that parcel.

(f) Bridges and Culverts. All private roads over any drainage, river, creek, etc. shall be traversed by a private bridge or culvert capable of supporting at least sixty thousand (60,000) pounds or such higher weight as deemed necessary and designated in writing by the Fire Marshal. Private bridges over twenty (20) feet long are not allowed. Private bridges and culverts shall be designed to handle a 25-year storm event; provided, if located in an area designated as a 100-year flood plain, then the design must meet the 100-year flood event. A letter stating that the private bridge or culvert design meets the requirements of this section must be submitted by a licensed Washington State Civil Engineer prior to construction and, for private bridges, every two (2) years thereafter.

(g) Access - Gradients.

- (1) For all developments accessed by private road, access shall be by at least one private road with a maximum gradient of twelve (12) percent or less; provided, such maximum gradient may be exceeded under either of the following circumstances:
  - (i) A maximum gradient of no more than fifteen (15) percent shall be permissible if the private road is surfaced with two (2) inches or more of asphalt or concrete; or
  - (ii) Subject to the written approval of the Fire Marshal, a maximum gradient of fifteen (15) percent may be allowed for less than two hundred (200) feet if such gradient is followed by a gradient of zero (0) percent for a period of six hundred (600) feet and adequately satisfies the vertical curve alignment necessary for the appropriate firefighting equipment. This design may be repeated as needed.
- (2) Notwithstanding subsection (1) above, the maximum gradient of a private road providing access to a dwelling unit shall not exceed twelve (12) percent at any point within two hundred (200) feet of an intersection of such private road with another private road or with a public road.
- (3) If requested, as-built drawings of each completed private road shall be submitted. The as-built drawing shall bear the stamp of a Washington State Registered Civil Engineer.

**Dead-end fire apparatus access roads more than 150' (feet) (45 720 mm) shall be provided with width and turnaround provisions in accordance with Table D103.4." A 120-foot Hammerhead, a 60-foot "Y", or 96-foot diameter cul-de-sac is required. (Examples supplied on page five of this handout)**

### **3.04.046 SPECIAL FIRE PROTECTION.**

**3.04.046 SPECIAL FIRE PROTECTION.** Notwithstanding other provisions of the International Building Code and/or the International Residential Code, the following restrictions shall apply:

(a) Except as set forth below, the use of cedar shakes or shingles or materials with similar flame spread characteristics for roof construction is prohibited.

- (1) Cedar shakes or shingles or materials with similar flame spread may be used for roof construction of dwelling units that:
  - (i) Are located in the Growth Management Act Agricultural District; and
  - (ii) Are setback a minimum of 150' from all property lines and other dwelling units; and
  - (iii) No other dwelling unit on the parcel/lot may have a cedar roof as described in (a) above.

(2) Class A, B, or C rated cedar shakes or shingles may be used for additions to existing structures that have cedar shake or shingle roofs and for existing roof repairs on structures of any type that have cedar shakes or shingles, provided the new fire rated shakes or shingles will not comprise fifty (50) percent or more of the existing roof within a twelve (12) month period.

(b) Non-combustible siding and soffit material is required on the downhill side of structures within thirty (30) feet of a fifteen (15) percent or greater grade.

(c) All structures within thirty (30) feet of the property line shall have non-combustible siding, soffits, or skirting on the side adjacent to an undeveloped area of natural vegetation that is in excess of five (5) contiguous acres, provided, that this restriction shall not apply to interior lots of platted parcels and development phases whose streets are accessible, and the water system is operational.

### **3.04.048 GRADES FIFTEEN (15) PERCENT OR STEEPER.**

When determined by the Fire Marshal, non-combustible siding/soffit/skirting shall be required on the downhill side(s) of the structure if within thirty (30) feet of fifteen (15) percent or greater grade. The grade will be determined by the predominant slope on the downhill side within a maximum of three hundred (300) feet.

**Purpose:** Provide for a uniform method for meeting the requirements of Benton County Code 3.18.045 Minimum Road Requirements.

**Scope:** This policy is applicable only to private roads as defined in Benton County Code 3.18.015. "Private Road" means a road, driveway or any form of access easement in excess of one-hundred and fifty (150') feet in length that is not dedicated to and maintained by Benton County."

**Procedure:** Upon the Benton County Fire Marshal's office receiving a submittal from the Benton County Planning Department or the Benton County Building Department, a review will be conducted to determine if the proposed private road meets the requirements of 3.18.045.

#### **12-foot-Wide Private Roads**

1. Road approval is required by the occupancy approval for a manufactured home, or by the final inspection for a site-built building.
2. Shall be permitted when serving six or less dwellings. A duplex count as two dwellings.
3. An approved turnaround is required when the private road length exceeds 150' (feet).
4. Turnouts shall be every 300 feet, and the surface shall be the same as the private road.
5. Maximum grade for nonpaved surfaces is 12%. For paved surfaces, it is 15%.
- 6. Radius for turns, curves, or switchbacks must be approved prior to construction.**
7. Stair stepping with **approved** vertical curves is permitted and may be repeated to the top.
8. Bridges and culverts must meet Benton County Code 3.18.045 (f). See Policy-Bridges/Culverts
9. Paved surfaces and compacted gravel surfaces shall be at least two inches thick.
  - Gravel surfaces shall meet the Base Course Standard
  - Professionals recommend gravel to be three inches thick.

- At three inches, a cubic yard will cover 108 sq. ft. (12' x 9') At two inches, a cubic yard will cover 162 sq. ft. (12' x 13.5') A truck and trailer carries 21.5 cubic yards.

### **20-foot-Wide Private Roads**

1. Road approval is required by the occupancy approval for a manufactured home, or by the final inspection for a site-built building.
2. An approved turnaround is required when the private road length exceeds 150' (feet).
3. Maximum grade for nonpaved surfaces is 12%. For paved surfaces, it is 15%.
4. **Radius for turns, curves, or switchbacks must be approved prior to construction**
5. Stair stepping with **approved** vertical curves is permitted and may be permitted to the top.
6. Bridges and culverts must meet Benton County Code 3.18.045 (f). See Policy-Bridges/Culverts
7. Paved surfaces and compacted gravel surfaces shall be at least two inches thick.
  - Gravel surfaces shall meet the Base Course Standard
  - Professionals recommend gravel to be three inches thick.
  - At three inches, a cubic yard will cover 108 sq. ft. (20' x 5.4') At two inches, a cubic yard will cover 162 sq. ft. (20' x 8') A truck and trailer carry 21.5 cubic yards.

### **Stair Stepping**

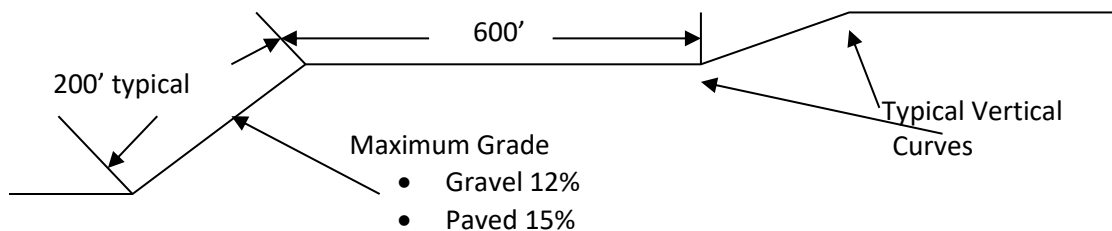

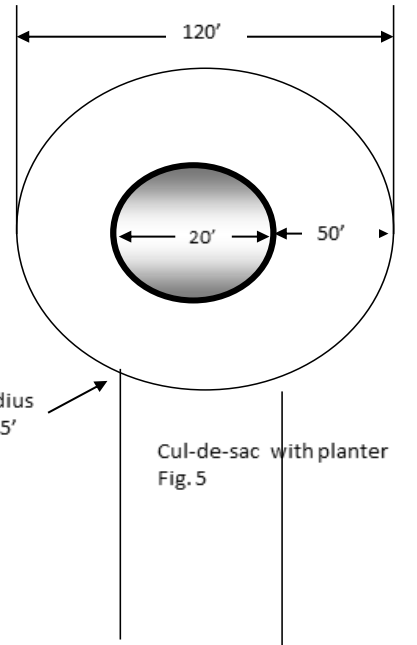
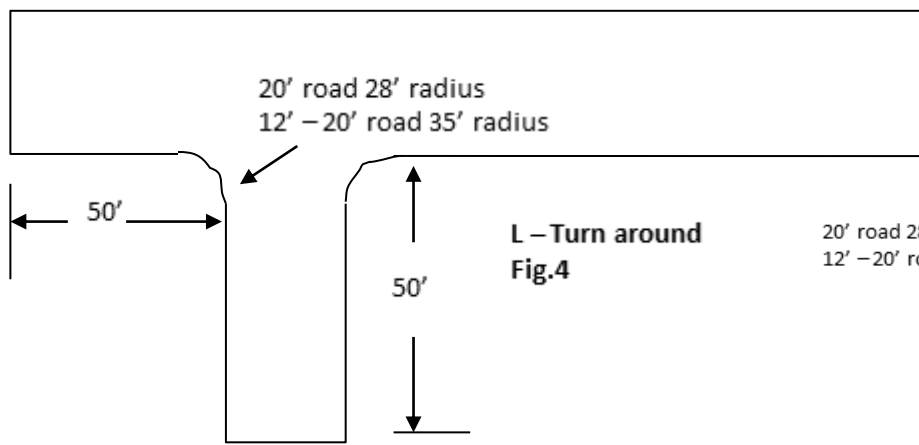
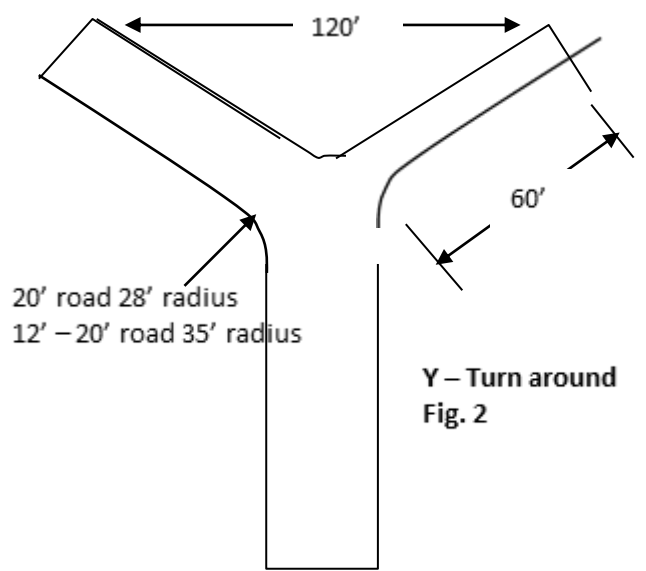
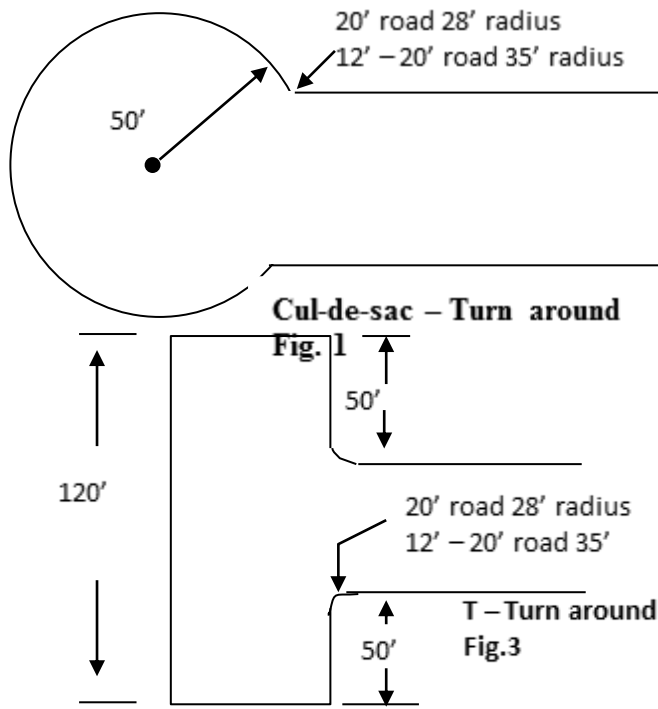

One of the problems that confront most of us, is how to construct a radius. Perhaps the following may be of assistance. From the corner, measure 28' in both directions. From points 1 and 2, measure 28'. Drive a large nail into the ground (point 3) and hook a string.

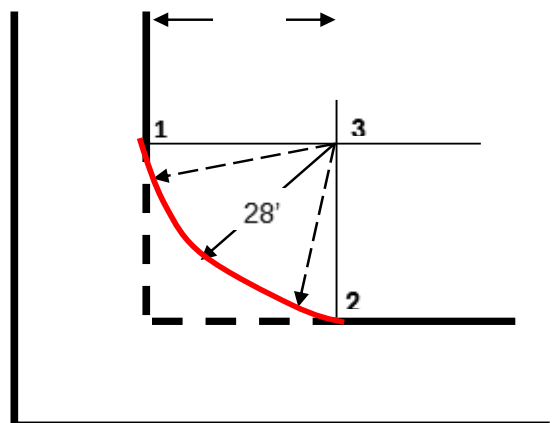

**Policy: Pullouts if your driveway exceeds 300 feet.**

**Purpose:**

Provide for a uniform method for meeting the requirements of Benton County Code 3.18.045 (b) \_

**Scope:**

This policy is applicable only to private roads as defined in Benton County Code 3.18.015 that are between 12 feet and 20 feet wide and whose length exceeds 300'. Private Road" means a road, driveway or any form of access easement in excess of one hundred and fifty (150') feet in length that is not dedicated to and maintained by Benton County."

**Procedure:**

Upon the Benton County Fire Marshal's office receiving a submittal from the Benton County Planning Department or the Benton County Building Department, a review will be conducted to determine if the proposed private road meets the requirements of 3.18.045 (b).

- The private road must comply with all sections of Benton County Code 3.18.045.
- The pullout shall be required every 300' (feet). Fig. 1
- Turnout surface shall be the same as the private road.
- Turnouts at a minimum shall be 10' x 30'.

Fig. 2

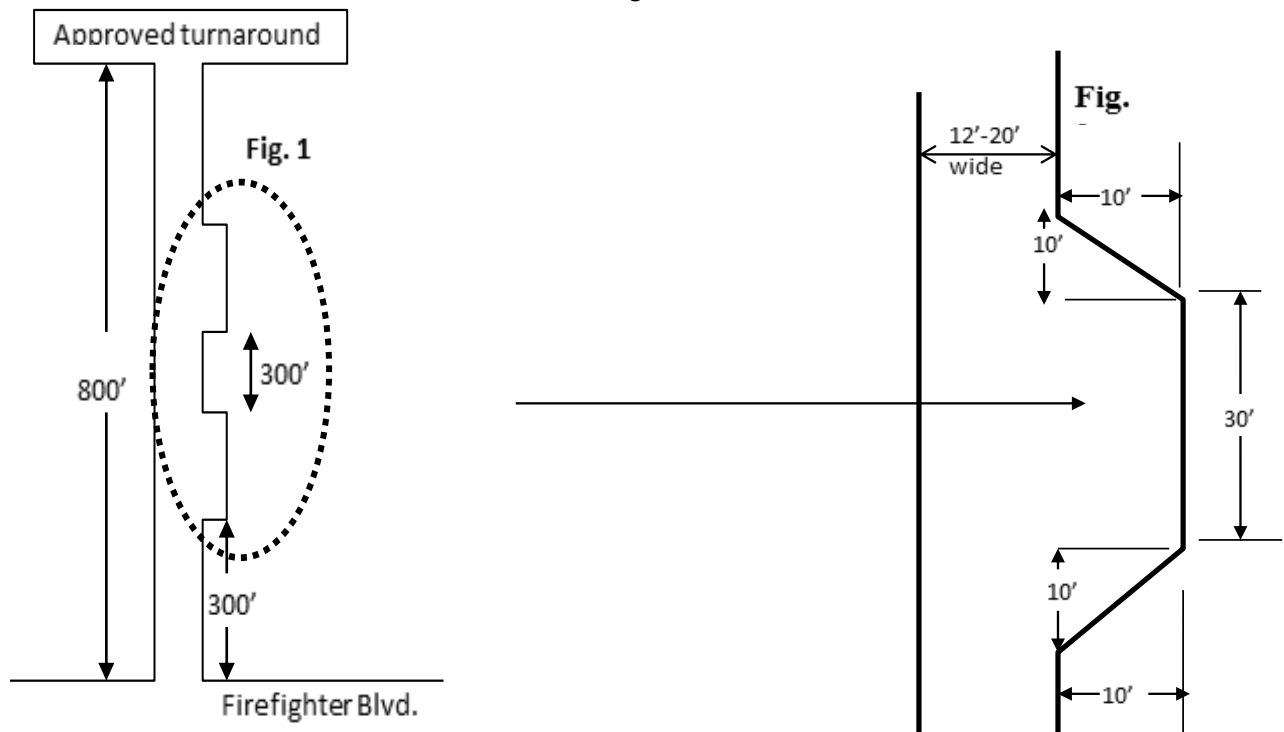

**Policy: BRIDGE DESIGN for Private Roads and Driveways.**

**Purpose:** Provide for a uniform method for the design and posting of private bridges.

**Scope:** This policy is applicable to private roads, private driveways, lanes, drives, access easements and similar driving surfaces. Bridges shall be inspected every two years.

**Procedure:** A Washington State Registered Civil Engineer shall design the bridge to meet, at a minimum, the following requirements.

- Both ends of the bridge are required to have the capacity posted. The signs shall have a pictograph showing the two below types of fire vehicles with the bridge capacity, in lbs. below each pictograph. See sample sign on page two for minimum sign and letter sizes.
- Benton County Fire Marshal shall approve Private bridges width. The bridge shall be designed and built to accommodate a **minimum, of a 75,000-pound truck**, or a 75,000-pound low-boy with the following dimensions:
- 75,000-pound truck
  - First axle to second axle is 150 inches
  - Second axle to third axle is 56 inches
  - Third axle to fourth axle is 60 inches

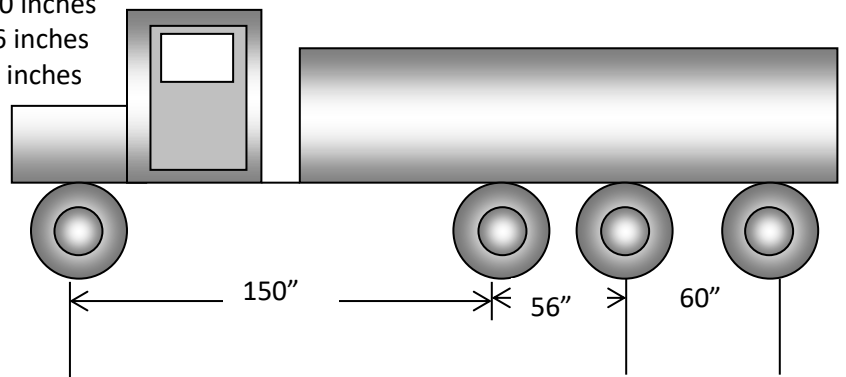

- 60,000-pound low boy
  - First axle to second axle is 142 inches.
  - Second axle to third axle is 52 inches.
  - Third axle to fourth axle is 470 inches.
  - Fourth axle to fifth axle is 48 inches.

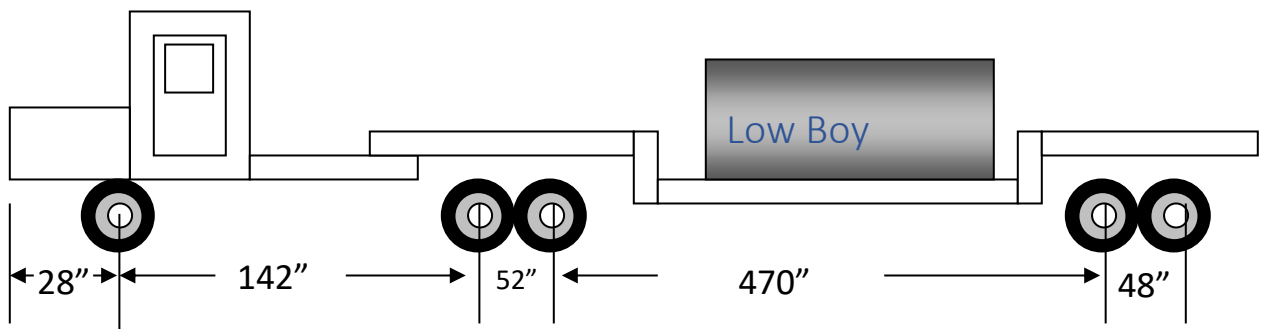

**Policy: CULVERT CROSSING**

**Purpose:** Provide for a uniform method for the design of culvert crossings.

**Scope:** This policy is applicable to private roads, private driveways, lanes, drives, access easements and similar driving surfaces.

**Procedure:** A Washington State Registered Civil Engineer shall design the culvert to meet, at a minimum, the following requirements. Upon the Benton County Fire Marshal’s office receiving a submittal from the Benton County Planning Department or the Benton County Building Department, a review will be conducted to determine if the proposed culvert meets the requirements of 3.18.045 (c).

- Benton County Code 3.18.045 (c) requires culverts to be designed to handle a 25-year storm and the imposed fire loads.
- Benton County Fire Marshal shall approve the design. The bridge shall be designed and built to accommodate, at a **minimum**, a 75,000-pound truck, or a 75,000-pound low-boy with the following dimensions:
- 75,000-pound truck
  - First axle to second axle is 150 inches
  - Second axle to third axle is 56 inches
  - Third axle to fourth axle is 60 inches

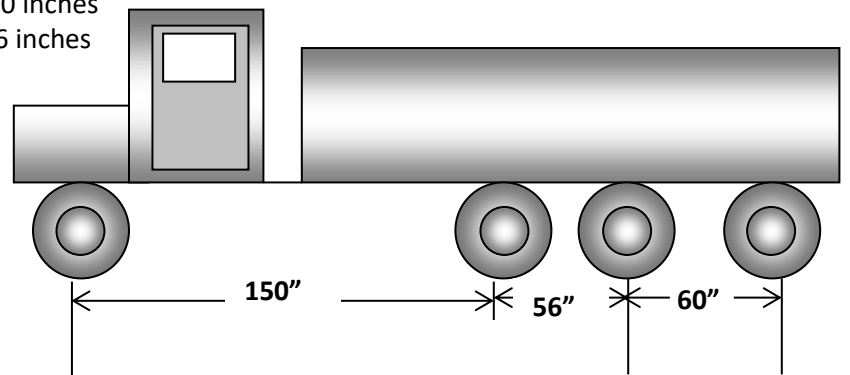

- 75,000-pound low boy
  - First axle to second axle is 142 inches.
  - Second axle to third axle is 52 inches.
  - Third axle to fourth axle is 470 inches.
  - Fourth axle to fifth axle is 48 inches.

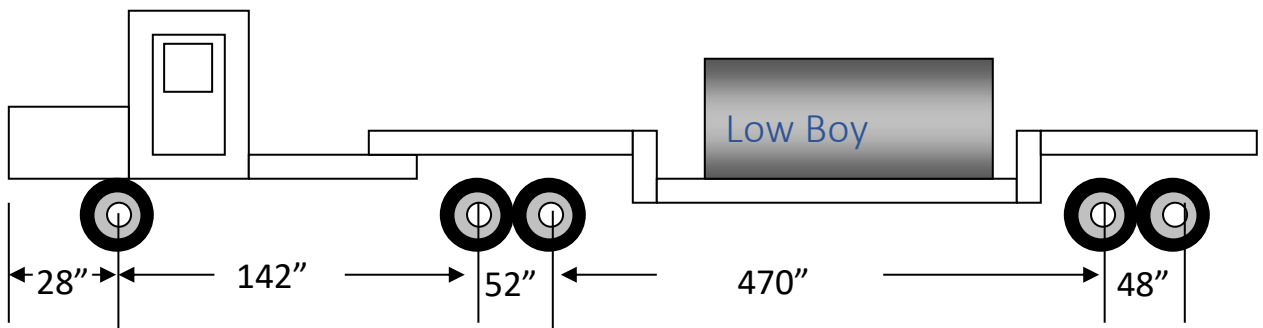

**Also, BCC 3.18.045 (i)**

- (i) Access Identification - Uniform Address Posts. Address locator posts shall be installed and maintained in accordance with the standards adopted by Benton County. (REQUIRED)  
The owner of the property is responsible for maintaining and replacing address locator posts per the following requirements and standards:
- (1) Address locator posts shall be perpendicular to the public right-of-way and shall be placed off the road so as not to hinder the movement of traffic and road maintenance vehicles.
  - (2) The posts shall be located adjacent to the private easement point of encroachment and/or driveway.
  - (3) If the address posts initially installed by the County are damaged, replacement of the address signs can be obtained from Benton County Planning/Building Department by submitting a fee as set by resolution of the Board of County Commissioners. In lieu of the fee, owners may provide their own signs.
  - (4) The posts must be at least four (4) and less than six (6) feet in height with reflective address numbers each at least four (4) inches in height on both sides.
  - (5) The address posts shall be flexible and shall not be hazardous to moving vehicles because of sign materials. Only posts approved by the County are allowed to be put on the public right of way.
  - (6) Address numbers shall be mounted on the structure in addition to the address locator posts. The address shall be placed on the side of the structure that faces the road. It should be placed near a doorway: if no doorway exists on the side of the structure facing the right-of-way, the numbers shall be placed four to six (4 - 6) feet above ground level. The numbers shall be a minimum of four (4) inches in height and shall contrast with their background.

**If you have questions on these requirements, please, feel free to contact the County Fire Marshal at (509) 735-3500. Ext 2411.**

**Gary Tiplady  
Benton County Fire Marshal**



NOTICE OF OPEN RECORD HEARINGS

# HEM 1.13

NOTICE IS HEREBY GIVEN that the following applications have been proposed to the Hearings Examiner for Benton County, Washington. An open public record hearing for the below stated applications will be held on **April 17, 2026** at 10 a.m. via in person and virtual meeting format in the Commissioners Room on the third floor of the Courthouse, 620 Market Street, Prosser WA. To find information on attendance options, please visit [www.tinyurl.com/BCPublicNotice](http://www.tinyurl.com/BCPublicNotice).

**CONDITIONAL USE PERMIT – CUP 2026-004** The applicant, Lexar Homes on behalf of Clinton and Anna Bush, is proposing to construct a 784 sq. ft. detached accessory dwelling unit on a parcel with an existing 3,702 sq. ft. single family residence. The project is located at 103730 Tatum Blvd, Kennewick, WA 99338.

**CONDITIONAL USE PERMIT – CUP 2026-005** The applicant, Juan Aguilar, is proposing to operate a painting business within an existing detached shop on a parcel a single family dwelling. The proposed project is located at 22206 E Kennedy Road, Benton City, WA 99320.

**CONDITIONAL USE PERMIT – CUP 2026-006** The applicants, Joshua and Marcia Walton, are proposing to construct an 800 sq. ft. detached accessory dwelling unit on a parcel with an existing 2,120 sq. ft. single family residence. The project is located at 50610 N Evert Road, Benton City, WA 99320.

**CONDITIONAL USE PERMIT – CUP 2026-007** The applicant, Intrigue Custom Homes on behalf of William and Cheryle Brasker, is proposing to construct a 796 sq. ft. detached accessory dwelling unit on a parcel with an existing 2,433 sq. ft. single family residence. The project is located at 2422 S 38<sup>th</sup> Avenue, West Richland, WA 99353.

**VARIANCE PERMIT – VAR 2026-001** The applicants, Robert and Helen Burke, are requesting to construct an attached RV garage to an existing residence and encroach 15 feet into the required 25 foot setback. The project is located at 36001 S Valley Vista PR SE, Kennewick WA 99338.

Questions can be directed to the Planning Division at 509-786-5612 or at [planning.department@co.benton.wa.us](mailto:planning.department@co.benton.wa.us). Written comments regarding the above applications must be received by **April 14, 2026** via email or submitted to the Planning Division office at the Public Services Building, 102206 E Wiser Parkway, Kennewick, WA 99338. Any information submitted to Benton County is subject to the public records disclosure laws for the State of Washington (RCW Chapter 42.17) and all other laws that may require the release of the documents to the public.

No individual with a disability shall be denied the benefit of participating in such meetings. If you wish to use auxiliary aids or require assistance to comment at a public meeting, please contact the Benton County Planning Division at least ten days prior to the meeting date to make arrangements for special needs.

Dated this 27th day of March, 2026.

PUBLICATION DATE: April 1, 2026

SUSAN E. DRUMMOND  
Benton County Hearings Examiner

Damien Hooper – Planning Manager  
Community Development Department